

OP-CFP2-LR4

100 Gb/s CFP2 LR4 Transceiver Module

PRODUCT FEATURES

- Compliant with 100GBASE-LR4 and 411-9D1F
- Support line rates from 103.125 Gbps to 111.81 Gbps
- Integrated LAN WDM EML TOSA / ROSA for up to 10 km reach over SMF
- Digital Diagnostics Monitoring Interface
- Duplex LC optical receptacle
- No external reference clock
- Single 3.3 V power supply
- Case operating temperature range: 0°C to 70°C
- Power dissipation < 6W

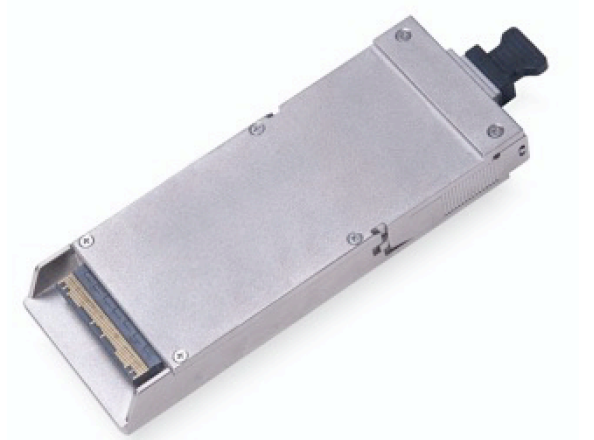

APPLICATIONS

- Data Center & 100G Ethernet
- ITU-T OTU4

STANDARD

- Compliant to IEEE 802.3ba and ITU-T G959.1
- Compliant to CFP MSA CFP2 Hardware Specification
- Compliant to CFP MSA CFP2 Management Interface Specification

General Description

OPTINET 100G CFP2 LR4 optical Transceiver integrates receiver and transmitter path on one module. In the transmit side, four lanes of serial data streams are recovered, retimed, and

passed to four laser drivers. The laser drivers control four EMLs (Electric-absorption Modulated Lasers) with center wavelength of 1296 nm, 1300nm, 1305nm and 1309 nm. The optical signals are multiplexed to a single –mode fiber through an industry standard LC connector. In the receive side, the four lanes of optical data streams are optically de-multiplexed by the integrated optical de-multiplexer. Each data stream is recovered by a PIN photo-detector and trans-impedance amplifier, retimed. This module features a hot-pluggable electrical interface, low power consumption and MDIO management interface.

The module provides an aggregated signaling rate from 103.125 Gbps to 111.81 Gbps. It is compliant with IEEE 802.3ba 100GBASE-LR4 and ITU-T G.959.1 411-9D1F, and OIF2010.404.08 CEI-28G-VSR electrical specifications. The MDIO management interface complies with IEEE 802.3ba standard. The transceiver complies with CFP MSA CFP2 Hardware Specification Rev. 1.0, CFP MSA Management Interface Specification, and OIF CEI-28G-VSR standards. A block diagram is shown in Figure 1.

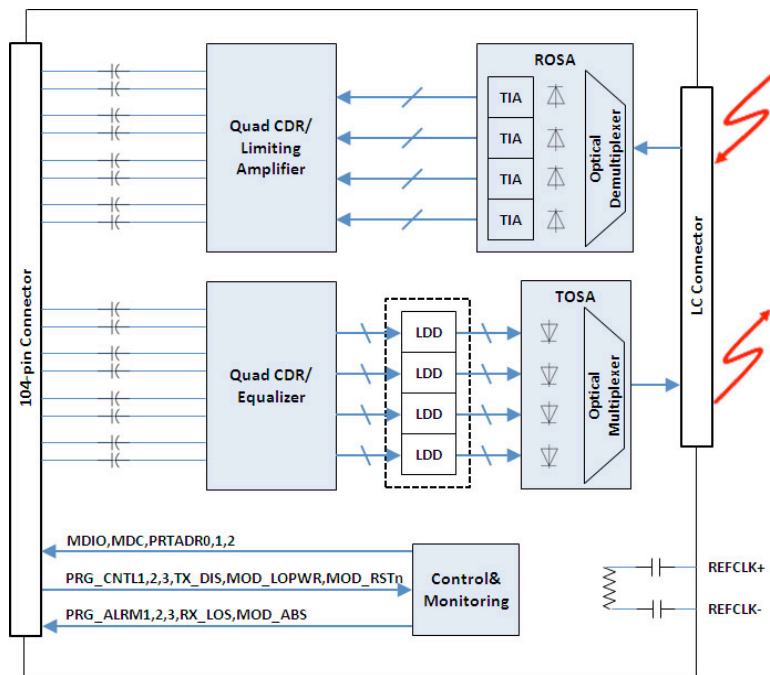

Figure 1. CFP2 LR4 Optical Transceiver functional block diagram

Transmitter

The transmitter path converts four lanes of serial NRZ electrical data from line rate of 25.78 Gbps to 27.95 Gbps to a standard compliant optical signal. Each signal path accepts a 100 Ω differential 100 mV peak-to-peak to 900 mV peak-to-peak 25 Gbps electrical signal on TDxn



Optinet Technology Co., Ltd

Add: 4th Floor Xiufeng Industrial Park, Buji Street, Longgang District, Shenzhen, China 518112

Tel: +86-755-28471034 Fax: +86-755-61824579

www.optinetec.com sales@optinetec.com

and TDxp pins. Inside the module, each differential pair of electric signals is input to a CDR (clock-data recovery) chip. The recovered and retimed signals are then passed to a laser driver which transforms the small swing voltage to an output modulation that drives a EML laser. The laser drivers control four EMLs with center wavelengths of 1296 nm, 1300 nm, 1305 nm and 1309 nm. The optical signals from the four lasers are multiplexed together optically. The combined optical signals are coupled to single-mode optical fiber through an industry standard LC optical connector.

Receiver

The receiver takes incoming combined four lanes optical data from line rate of 25.78 Gbps to 27.95 Gbps through an industry standard LC optical connector. The four incoming wavelengths are separated by an optical de-multiplexer into four separated channels. Each output is coupled to a PIN photo-detector. The electrical currents from each PIN photo-detector are converted to a voltage with a high-gain transimpedance amplifier. The electrical output is recovered and retimed by the CDR chip. The four lanes of reshaped electrical signals are output to RDxp and RDxn pins.

Low Speed Signaling

Low speed signaling is based on low voltage CMOS (LVCMOS) operating at a nominal voltage of 3.3 V for the control and alarm signals, and at a nominal voltage of 1.2 V for MDIO address, clock and data signals. All low speed inputs and outputs are based on the CFP MSA CFP2 Hardware Specification Rev. 1.0 and CFP MSA Management Interface Specification Rev. 2.2 requirements.

MDC/MDIO: Management interface clock and data lines.

PRTADR0, 1, 2: Input pins. MDIO physical port addresses.

GLB_ALEMn: Output pin. When asserted low indicates that the module has detected an alarm condition in any MDIO alarm register.

PRG_CNTL1, 2, 3: Input pins. Programmable control lines defined in the CFP MSA Management Interface Specification. Pulled up with 4.7 kΩ to 10 kΩ resistors to 3.3 V inside the CFP2 module.

TX_Disable: Input pin. When asserted high or left open the transmitter output is turned off. When Tx_Disable is asserted low or grounded the module transmitter is operating normally. Pulled up with 4.7 kΩ to 10 kΩ resistors to 3.3 V inside the CFP2 module.



MOD_LOPWR: Input pin. When asserted high or left open the CFP2 module is in low power mode. When asserted low or grounded the module is operating normally. Pulled up with 4.7 kΩ to 10 kΩ resistors to 3.3 V inside the CFP2 module.

MOD_RSTn: Input pin. When asserted low or grounded the module is in Reset mode. When asserted high or left open the CFP2 module is operating normally after an initialization process. Pulled down with 4.7 kΩ to 10 kΩ resistors to ground inside the CFP2 module.

PRG_ALARM1, 2, 3: Output pins. Programmable alarm lines defined in the CFP MSA Management Interface Specification.

Mod_ABS: Output pin. Asserted high when the CFP2 module is absent and is pulled low when the CFP2 module is inserted.

RX_LOS: Output pin. Asserted high when insufficient optical power for reliable signal reception is received.

Pin Function Definitions

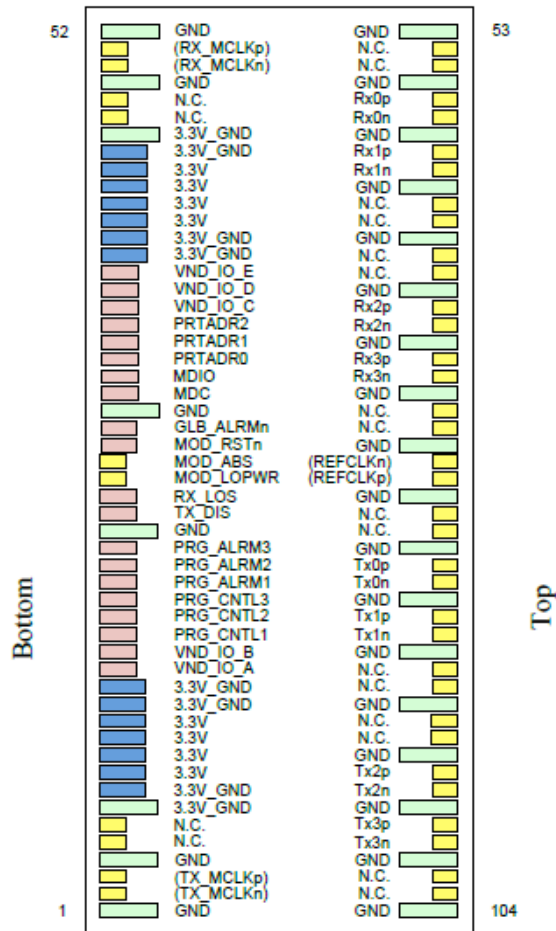

Figure 2 CFP2 optical transceiver pin-out
Table 1 CFP2 optical transceiver pin descriptions

Pin no.	Type	Name	Description
1		GND	Module ground
2	CML	(TX_MCLKn)	No connect
3	CML	(TX_MCLKp)	No connect
4		GND	Module ground
5		N.C.	No connect
6		N.C.	No connect
7		3.3V_GND	3.3V ground; tied with module ground
8		3.3V_GND	3.3V ground; tied with module ground
9		3.3V	3.3V module supply voltage
10		3.3V	3.3V module supply voltage
11		3.3V	3.3V module supply voltage
12		3.3V	3.3V module supply voltage
13		3.3V_GND	3.3V ground; tied with module ground
14		3.3V_GND	3.3V ground; tied with module ground
15		VND_IO_A	Module vendor IO A; do not connect
16		VND_IO_B	Module vendor IO B; do not connect
17	LVC MOS1	PRG_CNTL1	Programmable control 1; MSA default: TRXIC_RSTn; "0": reset; "1" or NC: not used
18	LVC MOS1	PRG_CNTL2	Programmable control 2; MSA default: Hardware interlock LSB; Default "0": ≤ 9 W
19	LVC MOS1	PRG_CNTL3	Programmable control 3; MSA default: Hardware interlock MSB; Default "1": ≤ 9 W
20	LVC MOS	PRG_ALARM1	Programmable alarm 1; MSA default: HIPWR_ON; "1": module power up completed, "0": module not high powered up
21	LVC MOS	PRG_ALARM2	Programmable alarm 2; MSA default: MOD_READY, "1": Ready, "0": not Ready
22	LVC MOS	PRG_ALARM3	Programmable alarm 3; MSA default: MOD_FAULT, "1": Fault, "0": no Fault
23		GND	Module ground
24	LVC MOS1	TX_DIS	Transmitter disable for all lanes; "1" or NC: transmitter disabled; "0": transmitter enabled
25	LVC MOS	RX_LOS	Receiver loss of optical signal; "1": low optical signal, "0": normal condition
26	LVC MOS1	MOD_LOPWR	Module low power mode; "1" or NC: module in low power mode, "0": power on enabled
27	GND	MOD_ABS	Module absent; "1" or NC: module absent; "0": module present. Pull up resistor on host.
28	LVC MOS2	MOD_RSTn	Module reset; "0": reset the module; "1" or NC: module enabled



Optinet Technology Co., Ltd

Add: 4th Floor Xiufeng Industrial Park, Buji Street, Longgang District, Shenzhen, China 518112

Tel: +86-755-28471034 Fax: +86-755-61824579

www.optinetec.com sales@optinetec.com

Pin no.	Type	Name	Description
29	LVC MOS	GLB_ALRMn	Global alarm; "0": alarm in any MDIO alarm register; "1": no alarm condition. Pull up resistor on host.
30		GND	Module ground
31	1.2V CMOS	MDC	Management interface clock input
32	1.2V CMOS	MDIO	Management interface bi-directional data
33	1.2V CMOS	PRTADR0	MDIO physical port address bit 0
34	1.2V CMOS	PRTADR1	MDIO physical port address bit 1
35	1.2V CMOS	PRTADR2	MDIO physical port address bit 2
36		VND_IO_C	Module vendor IO C; do not connect
37		VND_IO_D	Module vendor IO D; do not connect
38		VND_IO_E	Module vendor IO E; do not connect
39		3.3V_GND	3.3V ground; tied with module ground
40		3.3V_GND	3.3V ground; tied with module ground
41		3.3V	3.3V module supply voltage
42		3.3V	3.3V module supply voltage
43		3.3V	3.3V module supply voltage
44		3.3V	3.3V module supply voltage
45		3.3V_GND	3.3V ground; tied with module ground
46		3.3V_GND	3.3V ground; tied with module ground
47		N.C.	No connect
48		N.C.	No connect
49		GND	Module ground
50	CML	(RX_MCLKn)	No connect
51	CML	(RX_MCLKp)	No connect
52		GND	Module ground
53		GND	Module ground
54		N.C.	No connect
55		N.C.	No connect
56		GND	Module ground
57		RX0P	25 Gbps receiver data; Lane 0
58		RX0n	25 Gbps receiver data bar; Lane 0
59		GND	Module ground
60		RX1p	25 Gbps receiver data; Lane 1

Pin no.	Type	Name	Description
61		RX1n	25 Gbps receiver data bar; Lane 1
62		GND	Module ground



Optinet Technology Co., Ltd

Add: 4th Floor Xiufeng Industrial Park, Buji Street, Longgang District, Shenzhen, China 518112

Tel: +86-755-28471034 Fax: +86-755-61824579

www.optinetec.com sales@optinetec.com

63		N.C.	No connect
64		N.C.	No connect
65		GND	Module ground
66		N.C.	No connect
67		N.C.	No connect
68		GND	Module ground
69		RX2p	25 Gbps receiver data; Lane 2
70		RX2n	25 Gbps receiver data bar; Lane 2
71		GND	Module ground
72		RX3p	25 Gbps receiver data; Lane 3
73		RX3n	25 Gbps receiver data bar; Lane 3
74		GND	Module ground
75		N.C.	No connect
76		N.C.	No connect
77		GND	Module ground
78	CML	(REFCLKp)	Module reference clock. No connect.
79	CML	(REFCLKn)	Module reference clock. No connect.
80		GND	Module ground
81		N.C.	No connect
82		N.C.	No connect
83		GND	Module ground
84		TX0p	25 Gbps transmitter data; Lane 0
85		TX0n	25 Gbps transmitter data bar; Lane 0
86		GND	Module ground
87		TX1p	25 Gbps transmitter data; Lane 1
88		TX1n	25 Gbps transmitter data bar; Lane 1
89		GND	Module ground
90		N.C.	No connect
91		N.C.	No connect
92		GND	Module ground

Pin no.	Type	Name	Description
93		N.C.	No connect
94		N.C.	No connect
95		GND	Module ground
96		TX2p	25 Gbps transmitter data; Lane 2
97		TX2n	25 Gbps transmitter data bar; Lane 2
98		GND	Module ground



Optinet Technology Co., Ltd

Add: 4th Floor Xiufeng Industrial Park, Buji Street, Longgang District, Shenzhen, China 518112

Tel: +86-755-28471034 Fax: +86-755-61824579

www.optinetec.com sales@optinetec.com

99		TX3p	25 Gbps transmitter data; Lane 3
100		TX3n	25 Gbps transmitter data bar; Lane 3
101		GND	Module ground
102		N.C.	No connect
103		N.C.	No connect
104		GND	Module ground
1. Pulled up with 4.7 kΩ – 10 kΩ to 3.3 V inside the module.			
2. Pulled down with 4.7 kΩ – 10 kΩ to GND inside the module			

Absolute Maximum Ratings

Parameter	Symbol	Min.	Typ.	Max.	Unit	Note
Storage Temperature	Ts	-40	-	85	°C	
Relative Humidity	RH	5	-	95	%	
Power Supply Voltage	VCC	-0.3	-	4	V	
Signal Input Voltage		Vcc-0.3	-	Vcc+0.3	V	
Receive Input Optical Power (Damage threshold)	Pdmg			5.0	dBm	

Low Speed Electrical Characteristics

Parameter	Symbol	Min	Typ.	Max	Unit	Notes
Supply currents and voltages						
Voltage	Vcc	3.2	3.3	3.4	V	With Respect to GND
Supply current	Icc			1.8	A	
Power dissipation	Pwr			6.0	W	
Power dissipation (low power mode)	Plp			2.0	W	
Low speed control and sense signals, 3.3 V LVCMOS						
Outputs low voltage	VoL			0.2	V	I _{OH} =100 μA
Output high voltage	VoH	Vcc-0.2			V	I _{OH} =-100 μA
Input low voltage	ViL	-0.3		0.8	V	
Input high voltage	ViH	2		Vcc+ 0.3	V	
Input leakage current	IiN	-10		10	μA	
Low speed control and sense signals, 1.2 V LVCMOS						
Outputs low voltage	VoL	-0.3		0.2	V	
Output high voltage	VoH	1.0		1.5	V	
Output low current	I _{OL}	4			mA	
Output high current	I _{OH}			-4	mA	
Input low voltage	ViL	0.2		0.26	V	

**Optinet Technology Co., Ltd**

Add: 4th Floor Xiufeng Industrial Park, Buji Street, Longgang District, Shenzhen, China 518112

Tel: +86-755-28471034 Fax: +86-755-61824579

www.optinetec.com sales@optinetec.com

Input high voltage	V _{IH}	0.84		1.5	V	
Input leakage current	I _{IN}	-100		100	μA	
Input capacitance	C			10	pF	
MDC clock rate		0.1		4	MHz	

High Speed Electrical Specifications

Parameter	Symbol	Min	Max	Unit	Notes
Transmitter electrical input from host					
Differential voltage pk-pk		100	1200	mV	
Common mode noise (rms)			17.5	mV	
Differential termination mismatch			10	%	
Transition time		10		ps	20/80%
Common mode voltage		-0.3	2.8	V	
Eye width	EW15	0.46		UI	At 10 ⁻¹⁵ probability
Eye height	EH15	100		mV	At 10 ⁻¹⁵ probability
Receiver electrical output to host					
Differential voltage pk-pk		100	1200	mV	
Common mode noise (rms)			17.5	mV	
Differential termination mismatch			10	%	
Transition time		9.5		ps	20/80%
Vertical eye closure	VEC		6.5	dB	
Eye width	EW15	0.57		UI	At 10 ⁻¹⁵ probability
Eye height	EH15	240	mV		At 10 ⁻¹⁵ probability

MDIO Management Interface

The OPTINET CFP2 Optical Transceiver incorporates MDIO management interface which is used for serial ID, digital diagnostics, and certain control and status report functions. The CFP2 transceiver supports MDIO pages 8000h NVR 1 Based ID registers, 8080h NVR 2 Extended ID registers, 8100h NVR 3 network lane specific registers, and pages A000h CFP module VR 1 registers, A080h MLG VR 1 registers, A200h network lane VR 1 registers, A280h network lane VR 2 registers.

Details of the protocol and interface are explicitly described in CFP MSA Management Interface Specification. Please refer to the specifications for design reference.

Optical Characteristics

Specifications for 100Gbase-LR4

Parameter	Symbol	Min	Typ	Max	Unit	NOTE
Transmitter						
Signaling Speed per Lane			25.78125 ± 100 ppm		Gbps	
Wavelength Assignment	λ0	1294.53	1295.56	1296.59	nm	
	λ1	1299.02	1300.05	1301.09	nm	
	λ2	1303.54	1304.58	1305.63	nm	
	λ3	1308.09	1309.14	1310.19	nm	
Total Output. Power	P _{OUT}			10.5	dBm	
Transmit OMA per Lane		-1.3		4.5	dBm	
Average Launch Power Per lane		-4.3		4.5	dBm	
SMSR		30			dB	
Optical Extinction Ratio	ER	4			dB	
Average launch Power off per lane	P _{off}			-30	dBm	
RIN	RIN			-130	dB/Hz	
Output Eye Mask definition {X1, X2, X3, Y1, Y2, Y3}	{0.25, 0.4, 0.45, 0.25, 0.28, 0.4}					1
Receiver						
Signaling Speed per Lane			25.78125 ± 100 ppm		Gbps	
Wavelength Assignment		1294.53	1295.56	1296.59	nm	
		1299.02	1300.05	1301.09	nm	
		1303.54	1304.58	1305.63	nm	
		1308.09	1309.14	1310.19	nm	
Receive Power (OMA) per Lane	ROMA			4.5	dBm	
Average Input Power per Channel	RXP _x	-10.6		4.5	dBm	2
Receiver Sensitivity (OMA) per Lane	Rxsens			-8.6	dBm	
LOS De-Assert	LOSD	-30			dBm	
LOS Assert	LOSA			-12	dBm	
Receiver Reflectance	R _r			-26	dB	

Notes:



Optinet Technology Co., Ltd

Add: 4th Floor Xiufeng Industrial Park, Buji Street, Longgang District, Shenzhen, China 518112

Tel: +86-755-28471034 Fax: +86-755-61824579

www.optinetec.com sales@optinetec.com

2. Measured with a PRBS $2^{31}-1$ test pattern, @25.78Gb/s, BER < 10^{-12} .

Specifications for OUT4 4I1-9D1F

Parameter	Symbol	Min	Typ	Max	Unit	NOTE
Transmitter						
Signaling Speed per Lane			27.9525± 20 ppm		Gbps	
Wavelength Assignment	λ_0	1294.53	1295.56	1296.59	nm	
	λ_1	1299.02	1300.05	1301.09	nm	
	λ_2	1303.54	1304.58	1305.63	nm	
	λ_3	1308.09	1309.14	1310.19	nm	
Total Output. Power	P _{OUT}			8.9	dBm	
Average Launch Power Per lane		-2.5		2.9	dBm	
SMSR		30			dB	
Optical Extinction Ratio	ER	7			dB	
Average launch Power off per lane	P _{off}			-30	dBm	
Output Eye Mask definition {X1, X2, X3, Y1, Y2, Y3}	{0.25, 0.4, 0.45, 0.25, 0.28, 0.4}					3
Receiver						
Signaling Speed per Lane			27.9525± 20 ppm		Gbps	
Wavelength Assignment		1294.53	1295.56	1296.59	nm	
		1299.02	1300.05	1301.09	nm	
		1303.54	1304.58	1305.63	nm	
		1308.09	1309.14	1310.19	nm	
Average Input Power per Channel	RXP _x	-8.8		2.9	dBm	4
Equivalent Sensitivity per Channel	Rxsens			-10.3	dBm	
LOS De-Assert	LOSD	-30			dBm	
LOS Assert	LOSA			-12	dBm	
Receiver Reflectance	R _r			-26	dB	

Notes:

3. Hit ratio 5×10^{-5} .

4. Measured with a PRBS $2^{31}-1$ test pattern, @27.95Gb/s, BER < 10^{-12} .

Outline Dimensions

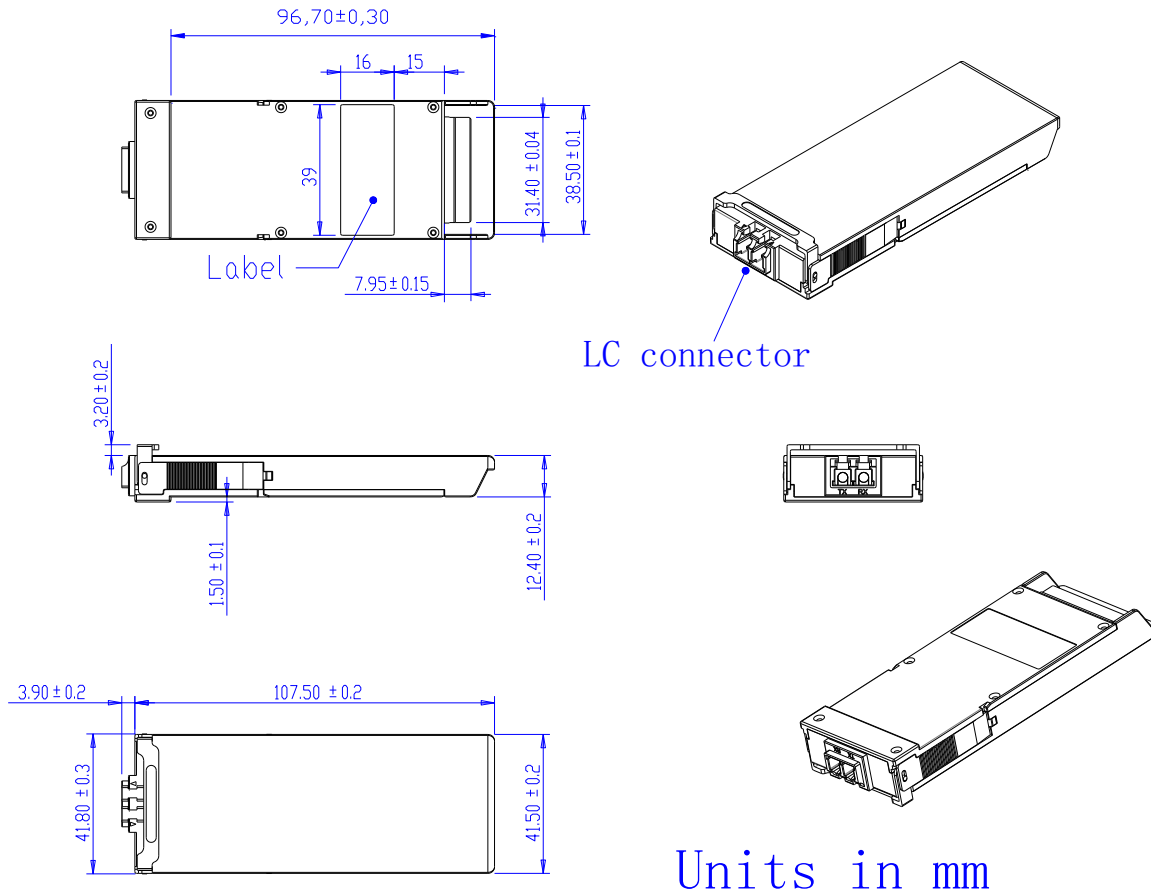

Ordering Information

Part Number	Product Description
OP-CFP2-LR4	100G CFP2 LR4 LWDM 10km LC DDM