



Optinet Technology Co., Ltd

Add: 4th Floor Xiufeng Industrial Park, Buji Street, Longgang District, Shenzhen, China 518112

Tel: +86-755-28471034 Fax: +86-755-61824579

www.optinetec.com sales@optinetec.com

## OP-S16G85-01

14.025Gbps SFP+ Transceiver, Multi Mode, 850nm 100m Reach

### Product Features

- Supports up to 14.025Gbps bit rates
- Hot-pluggable SFP+ footprint
- 850nm VCSEL laser and PIN photodiode, Up to 100m for OM3-MMF transmission
- Compliant with SFP+ MSA and SFF-8472 with duplex LC receptacle
- Compatible with RoHS
- Single +3.3V power supply
- Real Time Digital Diagnostic Monitoring
- Operating case temperature:
- Standard: 0 to +70°C



### Applications

- 4.25/8.5/14.025G Fibre channel

### Description

The SFP+ transceivers are high performance, cost effective modules supporting data rate of 14.025 Gbps.

Fiber type	Data rate (Gbps)	Operating range (meters)
OM2	4.25	0.5~150
	8.5	0.5~50
	14.025	0.5~35
OM3	4.25	0.5~380
	8.5	0.5~150
	14.025	0.5~100

The transceiver consists of three sections: a VCSEL laser transmitter, a PIN photodiode integrated with a trans-impedance preamplifier (TIA) and MCU control unit. All modules satisfy class I laser safety requirements.

The transceivers are compatible with SFP Multi-Source Agreement and SFF-8472 digital diagnostics functions.

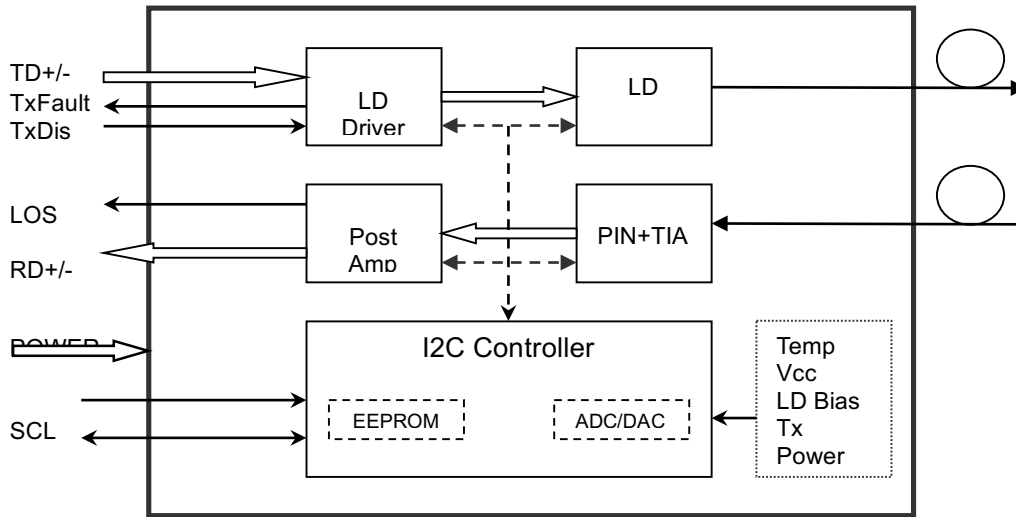

Transceiver functional diagram

### Absolute Maximum Ratings

Parameter	Symbol	Min	Max	Unit
Supply Voltage	Vcc	-0.5	4.5	V
Storage Temperature	Ts	-40	+85	°C
Operating Humidity	-	5	85	%

### Recommended Operating Conditions

Parameter	Symbol	Min	Typical	Max	Unit
Operating Case Temperature	Tc	0		+70	°C
Power Supply Voltage	Vcc	3.135	3.30	3.465	V
Power Supply Current	Icc			300	mA
Data Rate			14.025		Gbps

### Optical and Electrical Characteristics

Parameter	Symbol	Min	Typical	Max	Unit	Notes
<b>Transmitter</b>						
Centre Wavelength	$\lambda_c$	840	850	860	nm	
Spectral Width (RMS)	$\Delta\lambda$			0.59	nm	



Optinet Technology Co., Ltd

Add: 4th Floor Xiufeng Industrial Park, Buji Street, Longgang District, Shenzhen, China 518112

Tel: +86-755-28471034 Fax: +86-755-61824579

www.optinetec.com sales@optinetec.com

Side-Mode Suppression Ratio	SMSR	-	-	-	dB	
Average Output Power	P <sub>out</sub>	-7.8		-0.5	dBm	1
Extinction Ratio	ER	3.0			dB	
Data Input Swing Differential	V <sub>IN</sub>	180		950	mV	2
Input Differential Impedance	Z <sub>IN</sub>	90	100	110	Ω	
TX Disable	Disable	2.0		V <sub>cc</sub>	V	
	Enable	0		0.8	V	
TX Fault	Fault	2.0		V <sub>cc</sub>	V	
	Normal	0		0.8	V	
<b>Receiver</b>						
Centre Wavelength	λ <sub>c</sub>	840	850	860	nm	
Receiver Sensitivity				-10.5	dBm	3
Receiver Overload		0			dBm	3
LOS De-Assert	LOS <sub>D</sub>			-12	dBm	
LOS Assert	LOS <sub>A</sub>	-22			dBm	
LOS Hysteresis		0.5		4	dB	
Data Output Swing Differential	V <sub>out</sub>	500	700	900	mV	4
LOS	High	2.0		V <sub>cc</sub>	V	
	Low			0.8	V	

**Notes:**

1. The optical power is launched into MMF.
2. PECL input, internally AC-coupled and terminated.
3. Measured with a PRBS 2<sup>31</sup>-1 test pattern @14025Mbps, BER ≤1×10<sup>-12</sup>.
4. Internally AC-coupled.

## Timing and Electrical

Parameter	Symbol	Min	Typical	Max	Unit
Tx Disable Negate Time	t <sub>on</sub>			1	ms
Tx Disable Assert Time	t <sub>off</sub>			10	μs
Time To Initialize, including Reset of Tx Fault	t <sub>init</sub>			300	ms
Tx Fault Assert Time	t <sub>fault</sub>			100	μs



**Optinet Technology Co., Ltd**

Add: 4th Floor Xiufeng Industrial Park, Buji Street, Longgang District, Shenzhen, China 518112  
 Tel: +86-755-28471034 Fax: +86-755-61824579  
 www.optinetec.com sales@optinetec.com

Tx Disable To Reset	t_reset	10			μs
LOS Assert Time	t_loss_on			100	μs
LOS De-assert Time	t_loss_off			100	μs
Serial ID Clock Rate	f_serial_clock		100	400	KHz
MOD_DEF (0:2)-High	V <sub>H</sub>	2		V <sub>cc</sub>	V
MOD_DEF (0:2)-Low	V <sub>L</sub>			0.8	V

## Diagnostics

Parameter	Range	Unit	Accuracy	Calibration
Temperature	0 to +70	°C	±3°C	Internal
Voltage	3.0 to 3.6	V	±3%	Internal
Bias Current	0 to 15	mA	±10%	Internal
TX Power	-7.8 to -0.5	dBm	±3dB	Internal
RX Power	-16 to -1	dBm	±3dB	Internal

## Digital Diagnostic Memory Map

The transceivers provide serial ID memory contents and diagnostic information about the present operating conditions by the 2-wire serial interface (SCL, SDA).

The diagnostic information with internal calibration or external calibration all are implemented, including received power monitoring, transmitted power monitoring, bias current monitoring, supply voltage monitoring and temperature monitoring.

The digital diagnostic memory map specific data field defines as following.

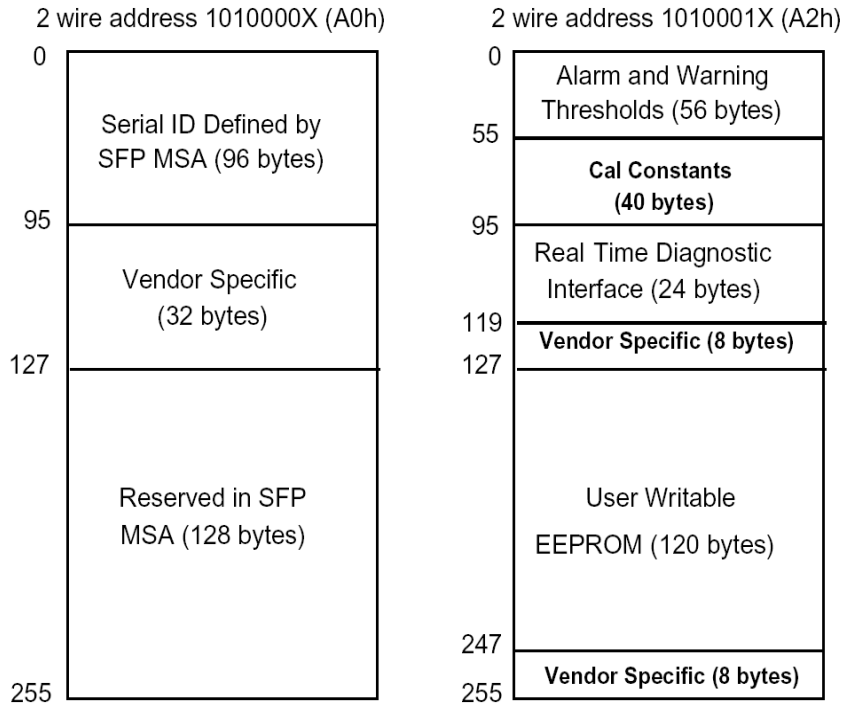

## Pin Descriptions

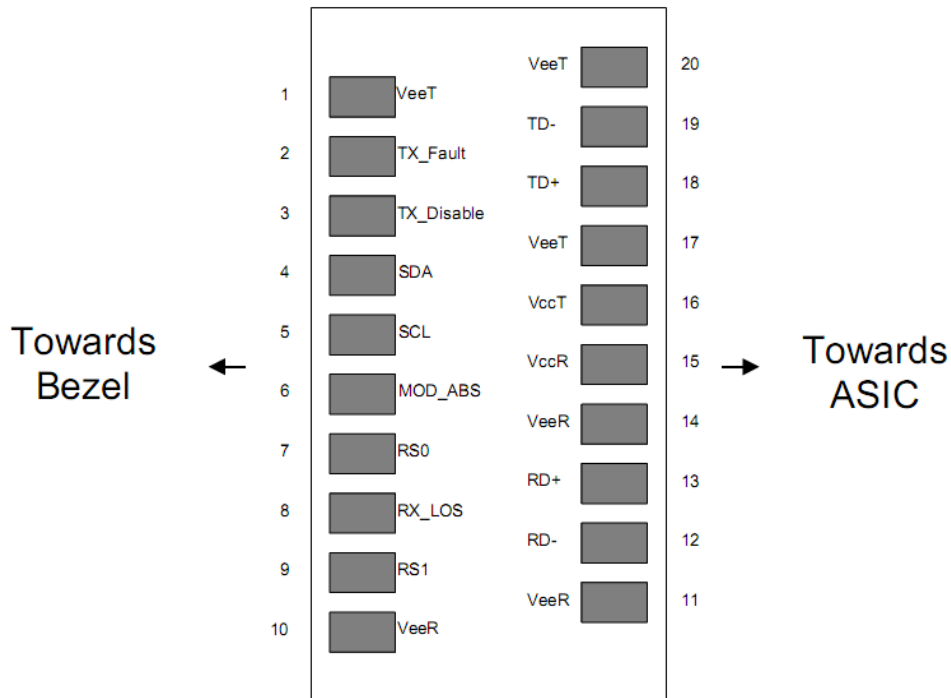



**Optinet Technology Co., Ltd**

Add: 4th Floor Xiufeng Industrial Park, Buji Street, Longgang District, Shenzhen, China 518112  
 Tel: +86-755-28471034 Fax: +86-755-61824579  
 www.optinetec.com sales@optinetec.com

Pin	Signal Name	Description	Plug Seq.	Notes
1	V <sub>EET</sub>	Transmitter Ground	1	
2	TX FAULT	Transmitter Fault Indication	3	Note 1
3	TX DISABLE	Transmitter Disable	3	Note 2
4	SDA	SDA Serial Data Signal	3	
5	SCL	SCL Serial Clock Signal	3	
6	MOD_ABS	Module Absent. Grounded within the module	3	
7	RS0	Not Connected	3	
8	LOS	Loss of Signal	3	Note 3
9	RS1	Not Connected	3	
10	V <sub>EER</sub>	Receiver ground	1	
11	V <sub>EER</sub>	Receiver ground	1	
12	RD-	Inv. Received Data Out	3	Note 4
13	RD+	Received Data Out	3	Note 4
14	V <sub>EER</sub>	Receiver ground	1	
15	V <sub>CCR</sub>	Receiver Power Supply	2	
16	V <sub>CCT</sub>	Transmitter Power Supply	2	
17	V <sub>EET</sub>	Transmitter Ground	1	
18	TD+	Transmit Data In	3	Note 5
19	TD-	Inv. Transmit Data In	3	Note 5
20	V <sub>EET</sub>	Transmitter Ground	1	

**Notes:**

Plug Seq.: Pin engagement sequence during hot plugging.

- 1) TX Fault is an open collector output, which should be pulled up with a 4.7k~10kΩ resistor on the host board to a voltage between 2.0V and V<sub>cc</sub>+0.3V. Logic 0 indicates normal operation; Logic 1 indicates a laser fault of some kind. In the low state, the output will be pulled to less than 0.8V.
- 2) Laser output disabled on TDIS >2.0V or open, enabled on TDIS <0.8V.
- 3) LOS is open collector output. Should be pulled up with 4.7k~10kΩ on host board to a voltage between 2.0V and 3.6V. Logic 0 indicates normal operation; logic 1 indicates loss of signal.
- 4) RD-/+ : These are the differential receiver outputs. They are internally AC-coupled 100 differential lines which should be terminated with 100Ω (differential) at the user SERDES.
- 5) TD-/+ : These are the differential transmitter inputs. They are internally AC-coupled, differential lines with 100Ω differential termination inside the module.

## Recommended Interface Circuit

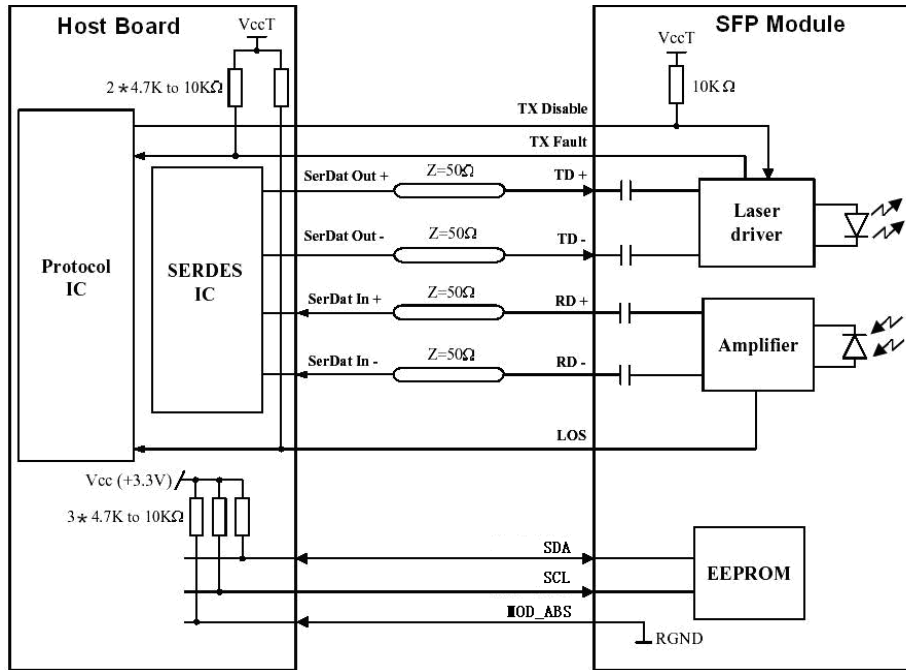

## Mechanical Dimensions

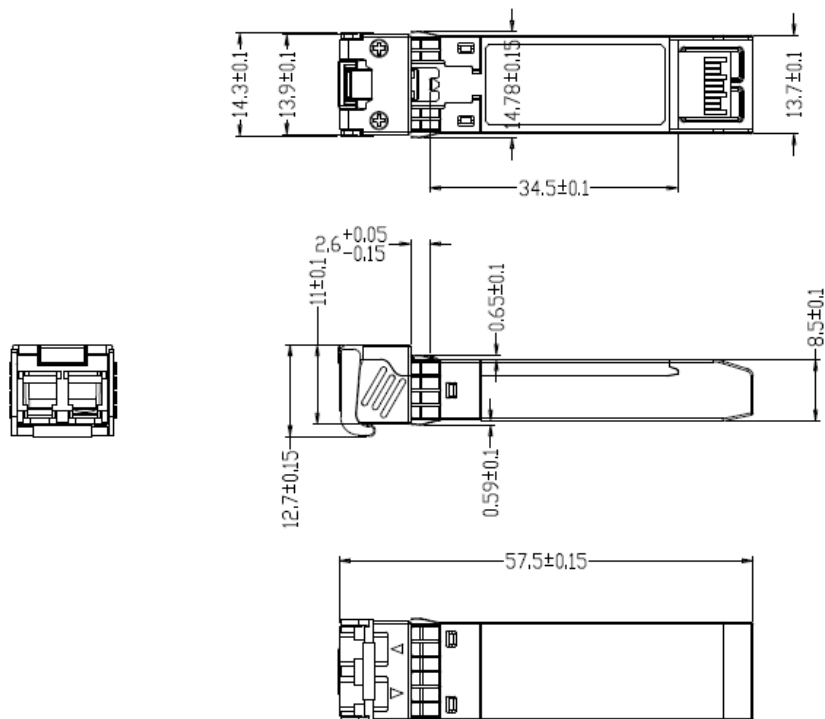



**Optinet Technology Co., Ltd**

Add: 4th Floor Xiufeng Industrial Park, Buji Street, Longgang District, Shenzhen, China 518112

Tel: +86-755-28471034 Fax: +86-755-61824579

www.optinetec.com sales@optinetec.com

## Ordering information

<b>Part Number</b>	<b>Product Description</b>
OP-S16G85-01	14.025Gbps 850nm 100m OM3 LC 0°C~+70°C