

OP-X10G31-40 10G XFP+ER Module, SM 1310nm 40km LC DDM

Features

- Support 9.95Gb/s to 11.1 Gb/s data rate
- Hot-pluggable XFP footprint
- Maximum link length of 40km on SMF
- 1310nm DFB laser and PIN photodiode
- XFI Loopback Mode
- Built-in digital diagnostic functions
- Single 3.3V power supply
- No reference clock required
- Duplex LC connector interface
- Low power consumption
- Compliant with RoHS



Applications

- 10GBASE-ER/EW Ethernet
- 10G Fibre Channel
- SONET OC-192&SDH STM-64

Description

OPTINET XFP+ER transceiver is compliant with the 10G Small Form-Factor Pluggable (XFP) Multi-Source Agreement (MSA).

The transceiver module comprises a transmitter with a 1310nm DFB laser and a receiver with PIN photodiode. Digital diagnostics functions are available via a 2-wire serial interface, as specified in the XFP MSA. The transceiver is RoHS compliant and lead free.

Absolute Maximum Ratings

Parameter	Symbol	Min.	Max.	Unit
Storage Temperature	Ts	-40	85	°C
Supply Voltage	Vcc	-0.5	4	V
Operating Humidity	RH	8	80	%
Power Consumption			1.5	W
Static Discharge Voltage on XFI High	HBM human body model perm JEDEC JESD22-A114-B		500	V
Static Discharge Voltage excluding XFI High	HBM human body model		2,000	V



Optinet Technology Co., Ltd

Add: 4th Floor Xiufeng Industrial Park, Buji Street, Longgang District, Shenzhen, China 518112

Tel: +86-755-28471034 Fax: +86-755-61824579

www.optinetec.com sales@optinetec.com

Speed Pins				
Static Discharge Voltage on XFP Module	EN61000-4-2 Criterion B:		15,000	V
	Air Discharge Direct		8,000	V
	Contact discharge			

Any stress beyond the maximum ratings can result in permanent damage.

The device specifications are guaranteed only under the recommended operating conditions.

Recommended Operating Conditions

Parameter	Symbol	Min.	Typical	Max.	Unit
Operating Case Temperature	Tc	0		70	°C
Power Supply Voltage	Vcc	3.15	3.3	3.45	V
Power Supply Current	Icc			450	mA

Optical Characteristics

Parameter	Symbol	Min.	Typical	Max.	Unit
Transmitter					
Centre Wavelength	λ_c	1290	1310	1330	nm
Average Output Power	Po	-1		4	dBm
Extinction Ratio	Er	8.2			dB
Side Mode Suppression Ratio	SMSR	30			dB
Average Launch power of OFF transmitter	POFF			-30	dBm
Transmitter and Dispersion Penalty	TDP			2	
Tx Jitter	Txj	Compliant with each standard requirements			
Receiver					
Center Wavelength	λ_c	1270		1610	nm
Receiver Sensitivity	S			-15	dBm
Stressed receiver sensitivity in OMA	RSENS			-14	dBm
Maximum Input Power	PMAX	0.5			dBm
LOS De-Assert	LOS _D			-16	dBm
LOS Assert	LOS _A	-30			dBm
LOS Hysteresis		0.5			dB

Notes:

1. The optical power is launched into SMF
2. Measured with a PRBS 2³¹-1 test pattern @10.3125Gbps



Optinet Technology Co., Ltd

Add: 4th Floor Xiufeng Industrial Park, Buji Street, Longgang District, Shenzhen, China 518112

Tel: +86-755-28471034 Fax: +86-755-61824579

www.optinetec.com sales@optinetec.com

Electrical Characteristics

Parameter	Symbol	Min.	Typ.	Max.	Unit
Transmitter					
Input Differential Impedance	Zin		100		Ω
Differential Data Input Swing	Vin	120		820	mV
Transmit Disable Voltage	VDis	2.0		VCC	
Transmit Enable Voltage	VEN	GND		GND+0.8	
Transmit Disable Assert Time				10	us
Receiver					
Differential Output Impedance	Vout				mV
Differential Output Amplitude	Zo		100		mV
Transition Time Low to High	tr			38	Ps
Transition Time High to Low	tf			38	ps
LOS Fault	L fault	Vcc-0.5		VCCHOST	V
LOS Normal	L normal	GND		GND+0.5	V

1. Maximum total power value is specified across the full temperature and voltage range.
2. Into 100 ohms differential termination.
3. These are unfiltered 20-80% values
4. Loss Of Signal is open collector to be pulled up with a 4.7k Ω – 10k Ω resistor to 3.15 – 3.6V. Logic 0 indicates normal operation; logic 1 indicates no signal detected.
5. Per Section 2.7.1. in the XFP MSA Specification

Digital Diagnostic Function

XFP transceivers provide digital diagnostic functions via a 2-wire serial interface, which allows real-time access to the following operating parameters: Transceiver temperature; Laser bias current; Transmitted optical power; Received optical power and Transceiver supply voltage.

It also provides a sophisticated system of alarm and warning flags, which may be used to alert end-users when particular operating parameters are outside of a factory-set normal range.

The digital diagnostic memory map specific data field defines as following.

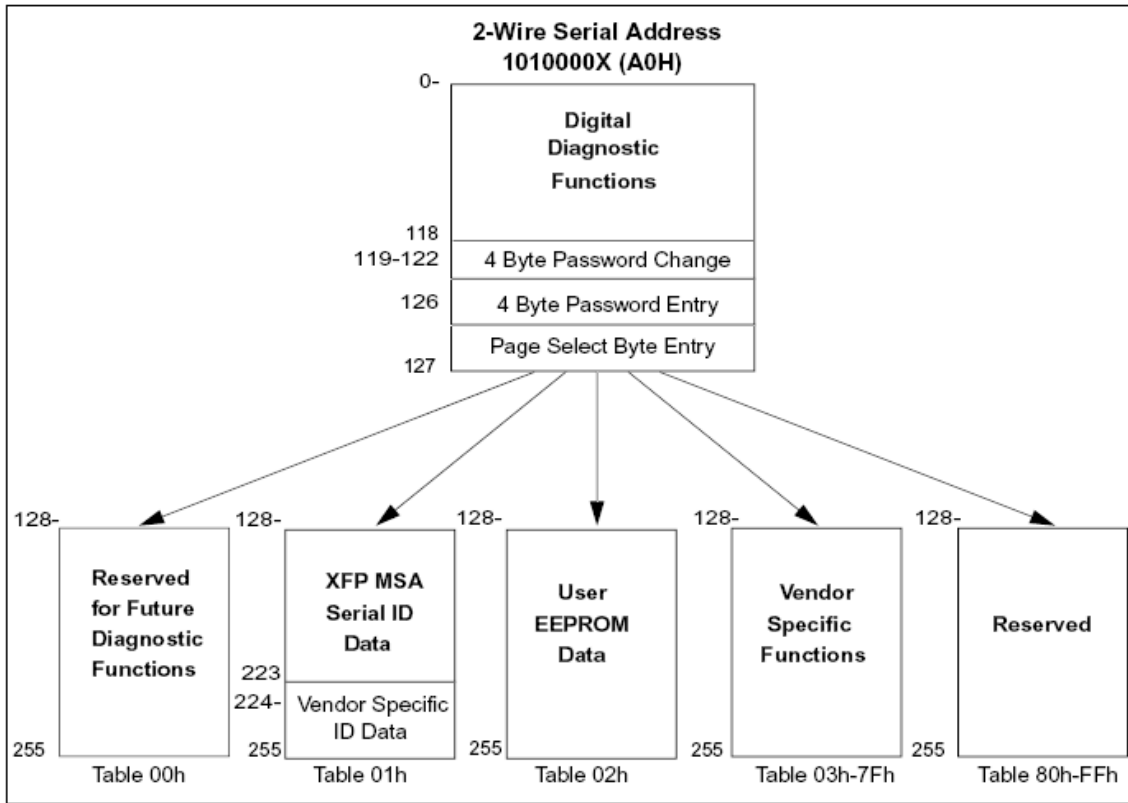

Pin Definitions

Diagram of Connector Block Pins on Host Board

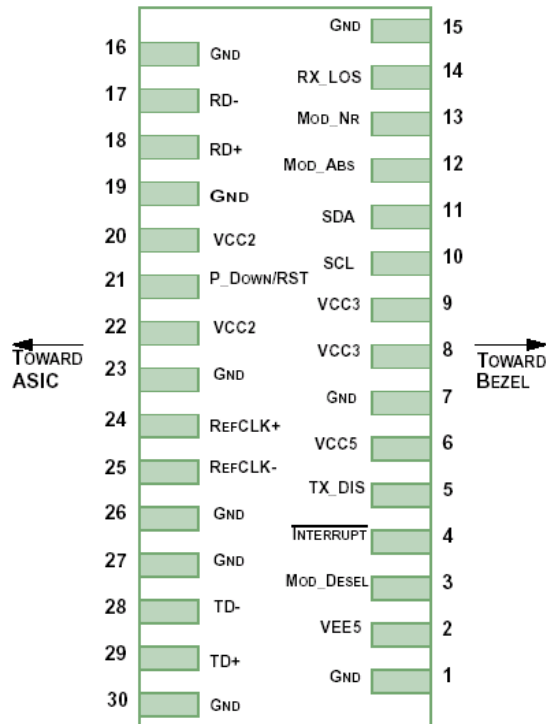

Pin Definitions

Pin	Logic	Symbol	Name/Description	Note
1		GND	Module Ground	1
2		VEE5	Optional -5.2V Power Supply (Not required)	
3	LVTTL-I	MOD_DESEL	Module De-select; When held low allows the module to respond to 2-wire serial interface	
4	LVTTL-O	INTb	Interrupt; Indicates presence of an important condition which can be read via the 2-wire serial interface	2
5	LVTTL-I	TX_DIS	Transmitter Disable; Turns off transmitter laser output	
6		VCC5	+5V Power Supply	
7		GND	Module Ground	1
8		VCC3	+3.3V Power Supply	
9		VCC3	+3.3V Power Supply	
10	LVTTL-I/O	SCL	2-Wire Serial Interface Clock	2
11	LVTTL-I/O	SDA	2-Wire Serial Interface Data Line	2
12	LVTTL-O	MOD_Abs	Indicates Module is not present. Grounded in the Module	2
13	LVTTL-O	MOD_NR	Module Not Ready; Indicating Module Operational Fault	2
14	LVTTL-O	RX_LOS	Receiver Loss Of Signal Indicator	2
15		GND	Module Ground	1
16		GND	Module Ground	1
17	CML-O	RDN	Receiver Inverted Data Output	
18	CML-O	RDP	Receiver Non-Inverted Data Output	
19		GND	Module Ground	1
20		VCC2	+1.8V Power Supply (Not required).	3
21	LVTTL-I	P_DOWN/RST	Power down; When high, requires the module to limit power consumption to 1.5W or below. 2-Wire serial interface must be functional in the low power mode.	
			Reset; The falling edge initiates a complete reset of the module including the 2-wire serial interface, equivalent to a power cycle.	
22		V _{CC2}	+1.8V Power Supply (Not required)	3
23		GND	Module Ground	1
24	PECL-I	REFCLKP	Not used, internally terminated to 50ohm (100ohm diff).	4
25	PECL-I	REFCLKN	Not used, internally terminated to 50ohm (100ohm diff).	4
26		GND	Module Ground	1
27		GND	Module Ground	1
28	CML-I	TDN	Transmitter Inverted Data Input	
29	CML-I	TDP	Transmitter Non-Inverted Data Input	
30		GND	Module Ground	1

1. Module ground pins GND are isolated from the module case and chassis ground within the module.
2. Open collector; Shall be pulled up with 4.7K-10Kohms to a voltage between 3.15V and 3.6V on the host board.
3. The pins are open within module.
4. Reference Clock is not required.

Notes:

1. Module ground pins GND are isolated from the module case and chassis ground within the module.
2. Shall be pulled up with 4.7kΩ-10 kΩ to a voltage between 3.15V and 3.45V on the host board

Recommended Host Board Power Supply Unit

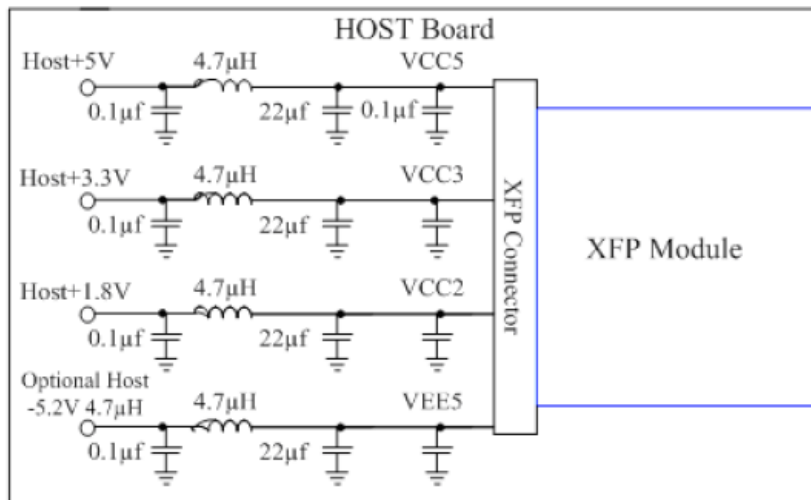

Recommended Interface Circuit

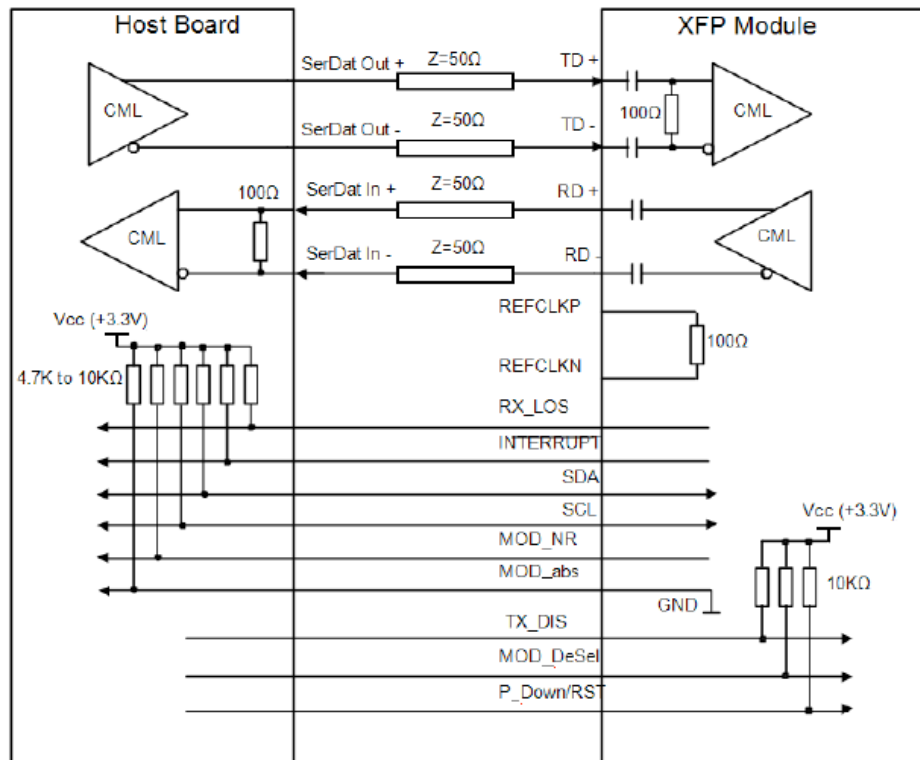

Mechanical Diagram

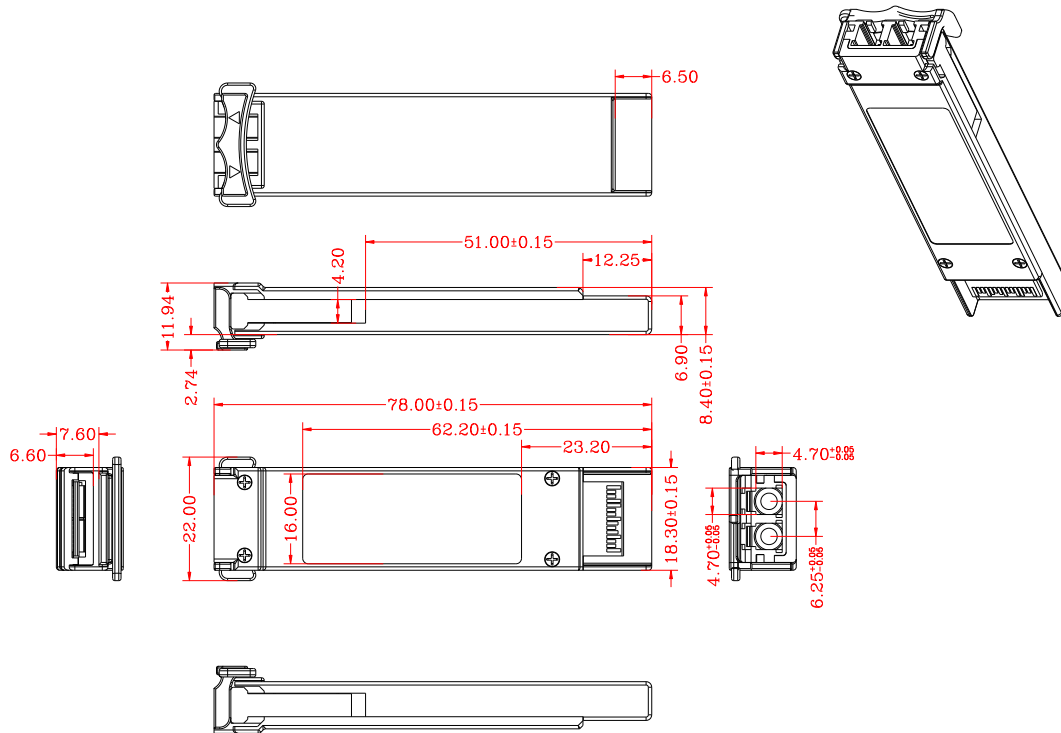

Ordering Information

Part No	Data Rate	Wavelength	Fiber	Reach	Temp	DDM
OP-X10G31-40	10Gbps	1310nm	SMF	40KM	0~70°C	YES
OP-X10G31-40E	10Gbps	1310nm	SMF	40KM	-10~80°C	YES
OP-X10G31-40I	10Gbps	1310nm	SMF	40KM	-40~85°C	YES

Warnings

Handling Precautions: This device is susceptible to damage as a result of electrostatic discharge(ESD). A static free environment is highly recommended. Follow guidelines according to proper ESD procedures.

Laser Safety: Radiation emitted by laser devices can be dangerous to human eyes. Avoid eye exposure to direct or indirect radiation.