

OP-S1GDXX-80 1.25Gbps DWDM 80KM SFP Transceiver

1. PRODUCT FEATURES

- Hot-pluggable SFP footprint
- Supports 1.25Gb/s bit rates
- DWDM wavelength EML transmitter, APD photo-detector
- Power dissipation < 1.5W
- Single 3.3V power supply
- Maximum link length of 80km
- Duplex LC connector
- Built-in digital diagnostic functions
- Case temperature range: 0°C to 70°C



2. APPLICATIONS

- Metro Access Rings
- Point-to-Point networking
- Gigabit Ethernet

3. PRODUCT DESCRIPTION

OP-S1GDXX-80 DWDM transceiver is designed for use in 1.25-Gigabit Ethernet links up to 80km over single mode fiber. The module consists of DWDM EML Laser, APD and Pre-amplifier in a high-integrated optical sub-assembly. Digital diagnostics functions are available via a 2-wire serial interface, as specified in SFF8472.

4. Absolute Maximum Ratings

Parameter	Symbol	Min.	Typ.	Max.	Unit	Note
Storage Temperature	Ts	-40		85	°C	
Storage Ambient Humidity	HA	5		85	%	
Power Supply Voltage	VCC	0		3.6	V	
Signal Input Voltage		-0.3		Vcc+0.3	V	

5. Recommended Operating Conditions

Parameter	Symbol	Min.	Typ.	Max.	Unit	Note
Operating Case Temperature	Tcase	0		70	°C	Note (1)

Ambient Humidity	HA	5		85	%	
Power Supply Voltage	VCC	3.14	3.3	3.46	V	
Power Supply Current	ICC			450	mA	
Power Supply Noise Rejection				100	mVp-p	100Hz to 1MHz
Transmission Distance				120	km	
Coupled fiber	Single mode fiber					ITU-T G.653

Note: -10 to 60degC with 1.5m/s airflow

6. Optical Characteristics

Parameter	Symbol	Min.	Typ.	Max.	Unit	Note
Transmitter						
Average Launched Power	PO	0		+5	dBm	Note (1)
Extinction Ratio	ER	6			dB	
Center Wavelength—End of Life	λ_c	X-100	X	X+100	pm	
Center Wavelength—Beginning of Life	λ_c	X-25	X	X+25	pm	
Center Wavelength Space			100		GHz	
Spectrum Band Width (RMS)	σ			1.0	nm	
SMSR		30			dB	
Transmitter OFF Output Power	POff			-40	dBm	
TX Jitter (peak-peak)	Txj			0.0	UI	
TX Jitter (RMS)	Txjrms			0.1	UI	
Transmitter and Dispersion Penalty	TDP			3.0	dB	
Output Eye Mask	Compliant with IEEE 0802.3ae					
Receiver						
Input Optical Wavelength	λ	1270		1610	nm	
Receiver Sensitivity				-30	dBm	Note (2)
Input Saturation Power (Overload)	Psat	-8			dBm	
LOS Detect -Assert Power	PA	-45			dBm	
LOS Detect - Deassert Power	PD			-33	dBm	
LOS Detect Hysteresis	PHYS	0.5		5	dB	

Note:

1. Launched power (avg.) is power coupled into a single mode fiber with master connector. (Before of Life)
2. Measured with conformance test signal for BER = 10^{-12} .@1.25Gbps, PRBS=2⁷-1,NRZ

7. Electrical Interface Characteristics

Parameter	Symbol	Min.	Typ.	Max.	Unit	Note
Transmitter						
Differential line input Impedance	RIN		100		Ohm	
Differential Data Input Swing	VDT	300		700	mVp-p	
Transmit Disable Voltage	Vdis	2		Vcc	V	LVTTL
Transmit Enable Voltage	Ven	Vee		Vee+0.8	V	
Receiver						
Differential Data Output Swing	VDR	400		850	mVp-p	Note (1)
LOS Output Voltage-High	VLOSH	Vee		Vee+0.8	V	LVTTL
LOS Output Voltage-Low	VLOSL	2		VccHOST	V	

Note: Into 100Ω differential termination.

8. Pin Description

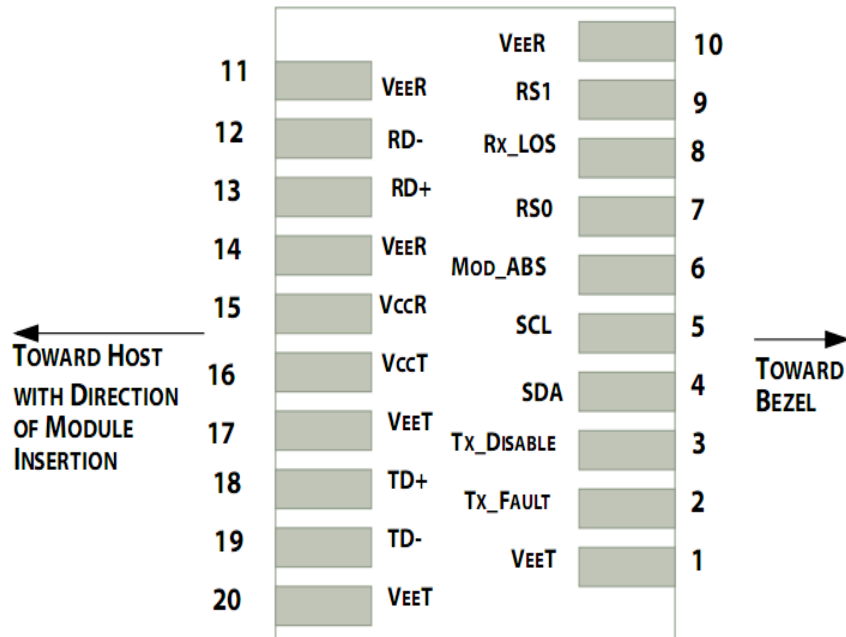

Pin out of Connector Block on Host Board

Pin	Symbol	Name/Description	Ref.
1	V_{EET}	Transmitter Ground (Common with Receiver Ground)	1
2	T_{FAULT}	Transmitter Fault.	2
3	T_{DIS}	Transmitter Disable. Laser output disabled on high or open.	3
4	SDA	2-wire Serial Interface Data Line	4
5	SCL	2-wire Serial Interface Clock Line	4
6	MOD_ABS	Module Absent. Grounded within the module	4
7	RS0	Rate Select 0	5
8	LOS	Loss of Signal indication. Logic 0 indicates normal operation.	6
9	RS1	No connection required	1
10	V_{EER}	Receiver Ground (Common with Transmitter Ground)	1
11	V_{EER}	Receiver Ground (Common with Transmitter Ground)	1
12	RD-	Receiver Inverted DATA out. AC Coupled	
13	RD+	Receiver Non-inverted DATA out. AC Coupled	
14	V_{EER}	Receiver Ground (Common with Transmitter Ground)	1
15	V_{CCR}	Receiver Power Supply	
16	V_{CCT}	Transmitter Power Supply	
17	V_{EET}	Transmitter Ground (Common with Receiver Ground)	1
18	TD+	Transmitter Non-Inverted DATA in. AC Coupled.	
19	TD-	Transmitter Inverted DATA in. AC Coupled.	
20	V_{EET}	Transmitter Ground (Common with Receiver Ground)	1

Notes:

1. Circuit ground is internally isolated from chassis ground.
2. T_{FAULT} is an open collector/drain output, which should be pulled up with a 4.7k – 10k Ohms resistor on the host board if intended for use. Pull up voltage should be between 2.0V to $V_{cc} + 0.3V$. A high output indicates a transmitter fault caused by either the TX bias current or the TX output power exceeding the preset alarm thresholds. A low output indicates normal operation. In the low state, the output is pulled to <0.8V.
3. Laser output disabled on $T_{DIS} > 2.0V$ or open, enabled on $T_{DIS} < 0.8V$.
4. Should be pulled up with 4.7kΩ- 10kΩ host board to a voltage between 2.0V and 3.6V. MOD_ABS pulls line low to indicate module is plugged in.
5. Internally pulled down per SFF-8431 Rev 4.1.
6. LOS is open collector output. It should be pulled up with 4.7kΩ – 10kΩ on host board to a voltage between 2.0V and 3.6V. Logic 0 indicates normal operation; logic 1 indicates loss of signal.

9. Recommended Interface Circuit

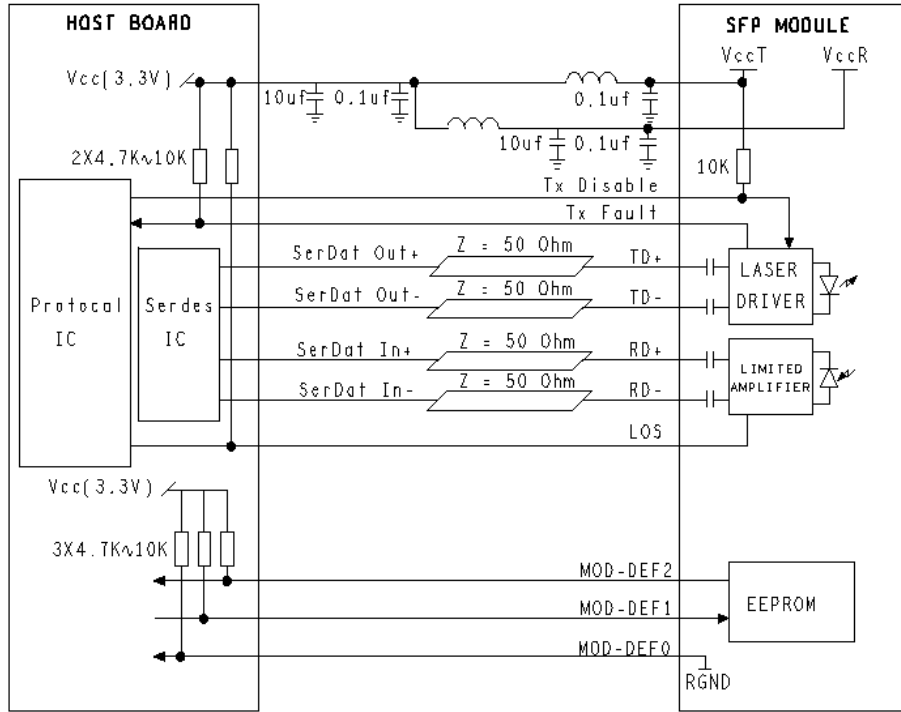

10. Outline Dimensions (mm)

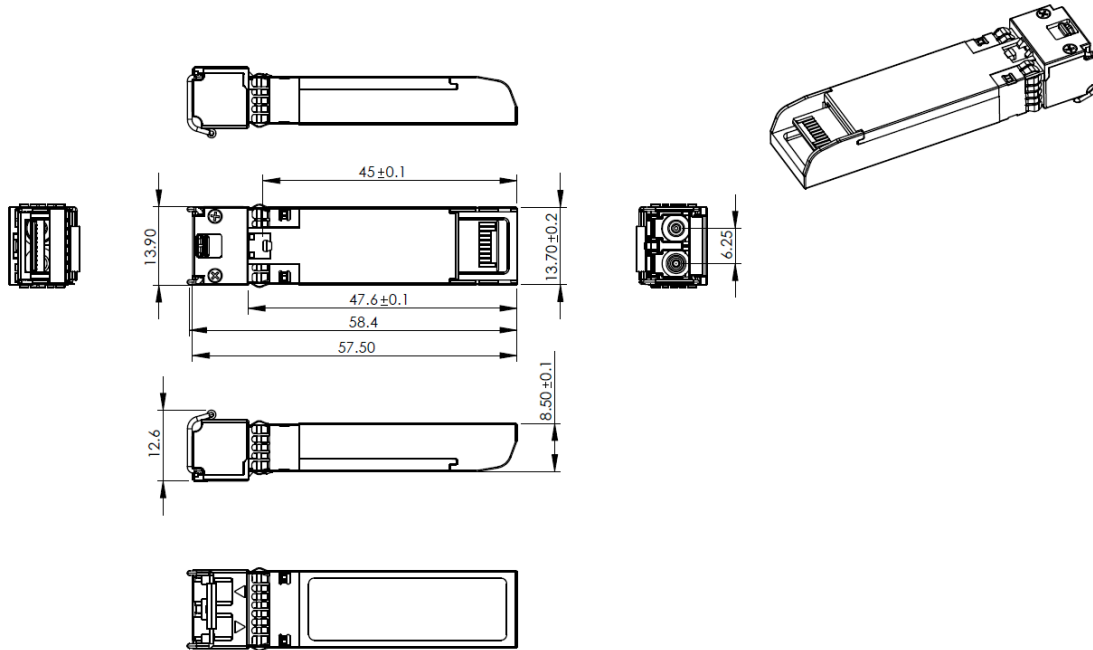



Optinet Technology Co., Ltd

Add: 4th Floor Xiufeng Industrial Park, Buji Street, Longgang District, Shenzhen, China 518112

Tel: +86-755-28471034 Fax: +86-755-61824579

www.optinetec.com sales@optinetec.com

C-band λ c Wavelength Guide

ITU Channel Product Code	Frequency (THz)	Wavelength	ITU Channel Product Code	Frequency (THz)	Wavelength
17	191.7	1563.86	40	194.0	1545.32
18	191.8	1563.05	41	194.1	1544.53
19	191.9	1562.23	42	194.2	1543.73
20	192.0	1561.42	43	194.3	1542.94
21	192.1	1560.61	44	194.4	1542.14
22	192.2	1559.79	45	194.5	1541.35
23	192.3	1558.98	46	194.6	1540.56
24	192.4	1558.17	47	194.7	1539.77
25	192.5	1557.36	48	194.8	1538.98
26	192.6	1556.55	49	194.9	1538.19
27	192.7	1555.75	50	195.0	1537.40
28	192.8	1554.94	51	195.1	1536.61
29	192.9	1554.13	52	195.2	1535.82
30	193.0	1553.33	53	195.3	1535.04
31	193.1	1552.52	54	195.4	1534.25
32	193.2	1551.72	55	195.5	1533.47
33	193.3	1550.92	56	195.6	1532.68
34	193.4	1550.12	57	195.7	1531.90
35	193.5	1549.32	58	195.8	1531.12
36	193.6	1548.51	59	195.9	1530.33



Optinet Technology Co., Ltd

Add: 4th Floor Xiufeng Industrial Park, Buji Street, Longgang District, Shenzhen, China 518112

Tel: +86-755-28471034 Fax: +86-755-61824579

www.optinetec.com sales@optinetec.com

37	193.7	1547.72	60	196.0	1529.55
38	193.8	1546.92	61	196.1	1528.77
39	193.9	1546.12			

Ordering Information

Part No	Data Rate	Wavelength	Reach	Temperature	DDM
OP-S1GDXX-80	1.25Gbps	100GHz C17-61	80KM	Commercial	Yes
OP-S1GDXX-80	1.25Gbps	50GHz C17-61	80KM	Commercial	Yes