

## OP-GPON-C+++ GPON OLT SFP C+++, 2.488G Tx1490, 1.244G Rx1310 20km SC

### Product Features

- Support ITU-T G.984.2 GPON OLT C+++ application
- Single fiber bi-directional data links with symmetric 2.488Gbps Tx and 1.244Gbps Rx
- 1490nm continuous-mode transmitter with DFB LD
- 1310nm burst-mode receiver with APD-TIA
- 2-wire interface for integrated digital diagnostic Monitoring
- Receiver RESET, Signal Detect, RSSI function indication (RESET, RX\_SD, RSSI)
- SFP package with SC/UPC receptacle optical interface
- Operation temperature 0-70°C for Commercial, -10~85°C for Extended, -40~85°C for industrial
- Single +3.3V power supply
- RoHS6 compliance



### Operating Condition

Parameter	Unit	Min.	Typical	Max.
Storage Temperature	°C	-40		85
Operating Case Temp for C-temp	°C	0		70
Operating Case Temp for I-temp	°C	-40		85
Operating Relative Humidity	%	5		95
Power Supply Voltage	V	3.15	3.3	3.45
Supply Current	mA			600
Bit Rate for Tx	Gbps		2.488	
Bit Rate for Rx	Gbps		1.244	

### Characteristics

All performance is specified at whole working temperature and conditions

Parameter	Unit	Min.	Typical	Max.
<b>Transmitter</b>				
TX Central Wavelength	nm	1480	1490	1500
Spectral Width (-20dB)	nm			1
Side Mode Suppression Ratio (SMSR)	dB	30		
Mean Launched Power	dBm	7		9
Mean Launched Power (TX Off)	dBm			-45
Extinction Ratio	dB	8.2		
Optical Return Loss Tolerance	dB	-12		
Transmitter and dispersion Penalty	dB			1

Receive Wavelength	nm	1290	1310	1330
Sensitivity (PRBS2 <sup>23</sup> -1@1.244G, ER=10, BER<10 <sup>-10</sup> )	dBm			-32
Overload (PRBS2 <sup>23</sup> -1@1.244G, ER=10, BER<10 <sup>-10</sup> )	dBm	-12		
Receiver Burst Mode Dynamic Range	dB	15		
Damage Threshold for Receiver	dBm	5		
SD Assert Level	dBm			-33
SD De-assert Level	dBm	-45		
SD Hysteresis	dB	0.5		6
WDM Filter isolation to 1550nm	dB	38		
WDM Filter isolation to 1650nm	dB	35		
<b>Electrical Interface Characteristics</b>				
Data Input Swing Differential/TX	mV	200	-	2000
Data Output Swing Differential/RX	mV	400		1600
Date Differential Impedance	Ω	90	100	110
LVTTL Output High	V	2.4		Vcc
LVTTL Output Low	V	0		0.4
LVTTL Input High	V	2.0		Vcc+0.3
LVTTL Input Low	V	0		0.8
<b>Timing Characteristics</b>				
Guard Time (Tg)	ns	25.6		
Reset Pulse Width (Tr)	ns			12.8
Reset Delay (Trd)	ns			12.8
Receiver Preamble Time (Tp)	ns			140
SD Assert Time (TSDA)	ns			100
SD De-assert Time (TSDD)	ns			12.8
RSSI Trigger Delay (Ttd)	ns	25		
RSSI Trigger Pulse Width (Tw)	ns	500		
Internal I2C Delay (Twait)	us			500

## Timing Sequence for RSSI

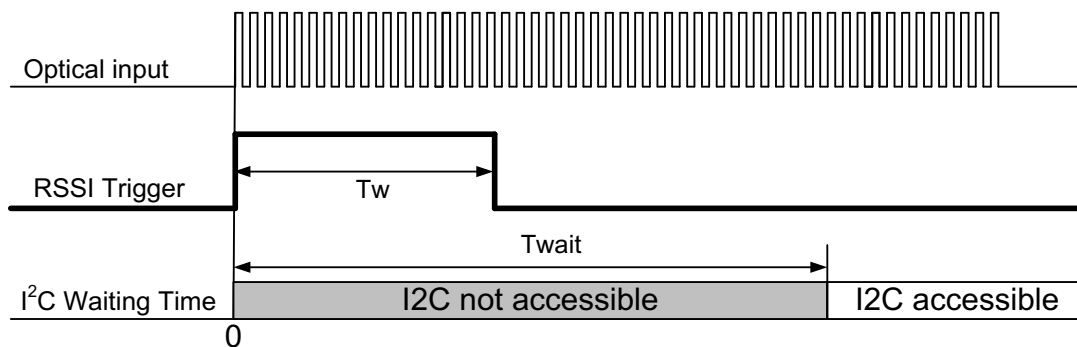

### Timing Sequence for Ranging Mode

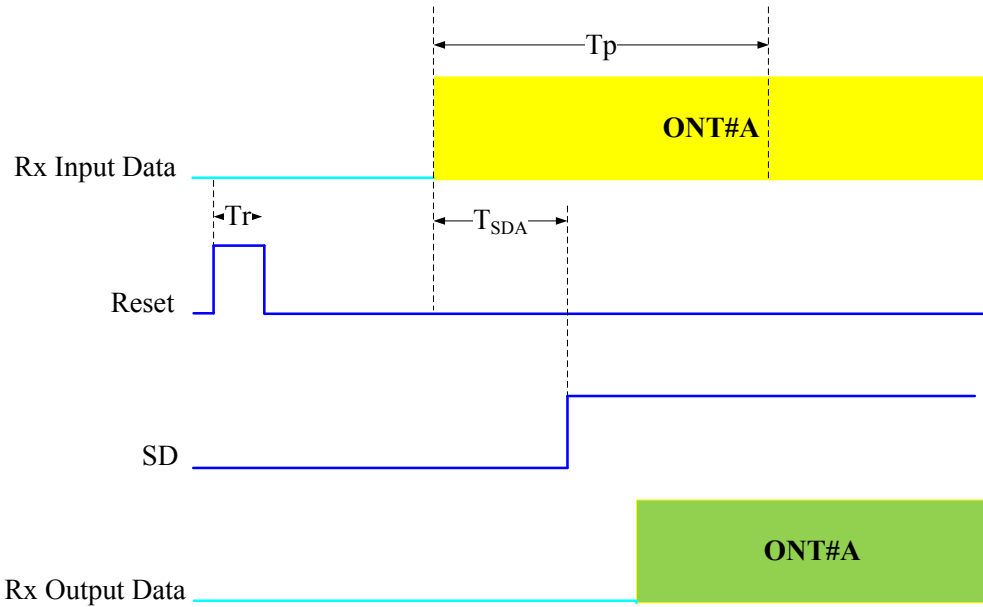

### Timing Sequence for Working Mode

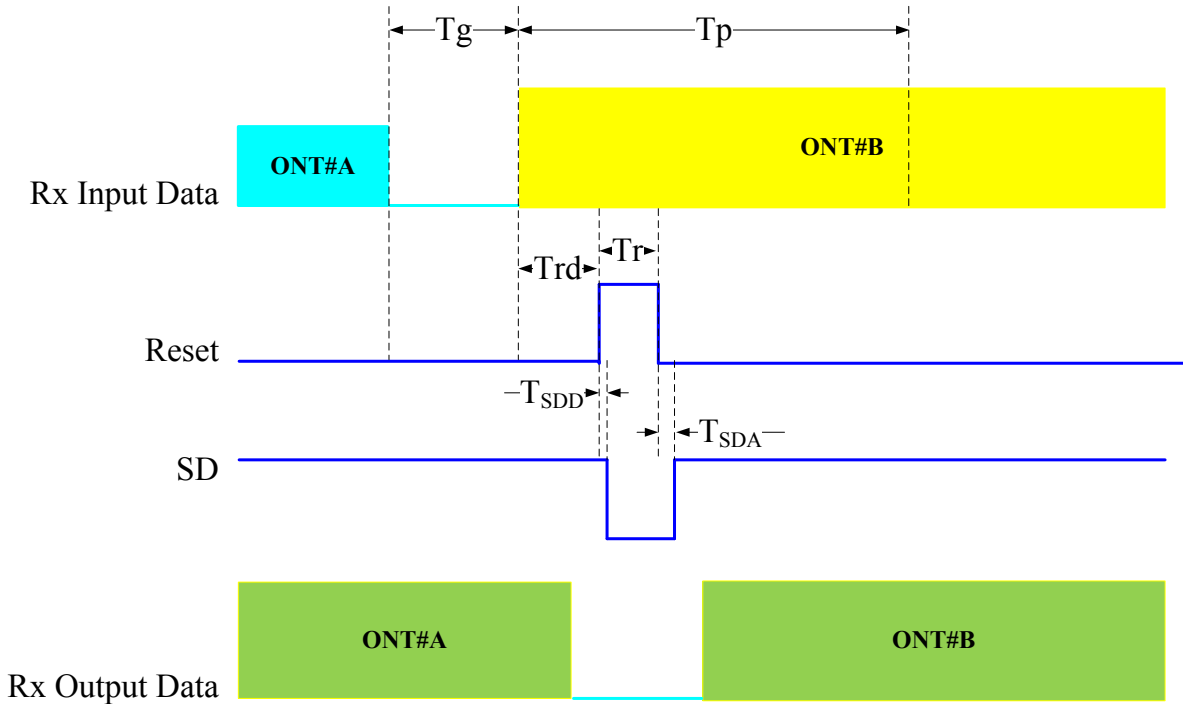

## Pin Definitions

Pin No.	Symbol	Level / Logic	Description
1	VeeT		Module Transmitter Ground
2	Tx_Fault	LVTTTL-O	Module Transmitter Fault
3	Tx_DIS	LVTTTL-I	Laser output is disabled when this pin is asserted high or left unconnected
4	SDA	LVTTTL-I	2-Wire Serial Interface Data Line
5	SCL	LVTTTL-I/O	2-Wire Serial Interface Clock
6	MOD_ABS	LVTTTL-O	Module Absent, connected to ground in the module
7	RX_Reset	LVTTTL-I	Receiver RESET signal
8	RX_SD	LVTTTL-O	Receiver Signal Detected Indication
9	RSSI_TRIG	LVTTTL-I	Receiver RSSI Trigger signal
10	VeeR		Module Receiver Ground
11	VeeR		Module Receiver Ground
12	RD-	LVPECL-O	Receiver Inverted Data Output
13	RD+	LVPECL-O	Receiver Non-Inverted Data Output
14	VeeR		Module Receiver Ground
15	VccR		Module Receiver 3.3V Supply
16	VccT		Module Transmitter 3.3V Supply
17	VeeT		Module Transmitter Ground
18	TD+	LVPECL-I	Transmitter Non-Inverted Data Input
19	TD-	LVPECL-I	Transmitter Inverted Data Input
20	VeeT		Module Transmitter Ground

## EEPROM Information

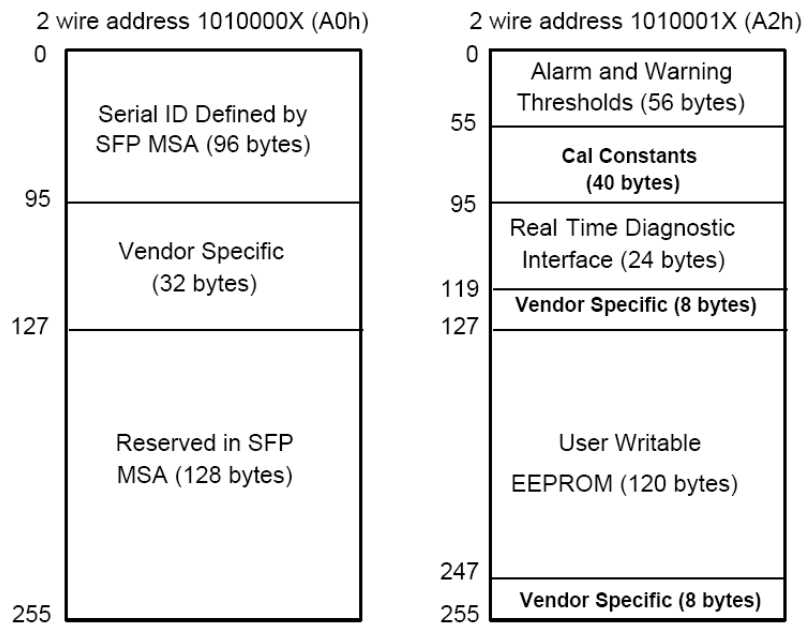

## Recommended Interface Circuit

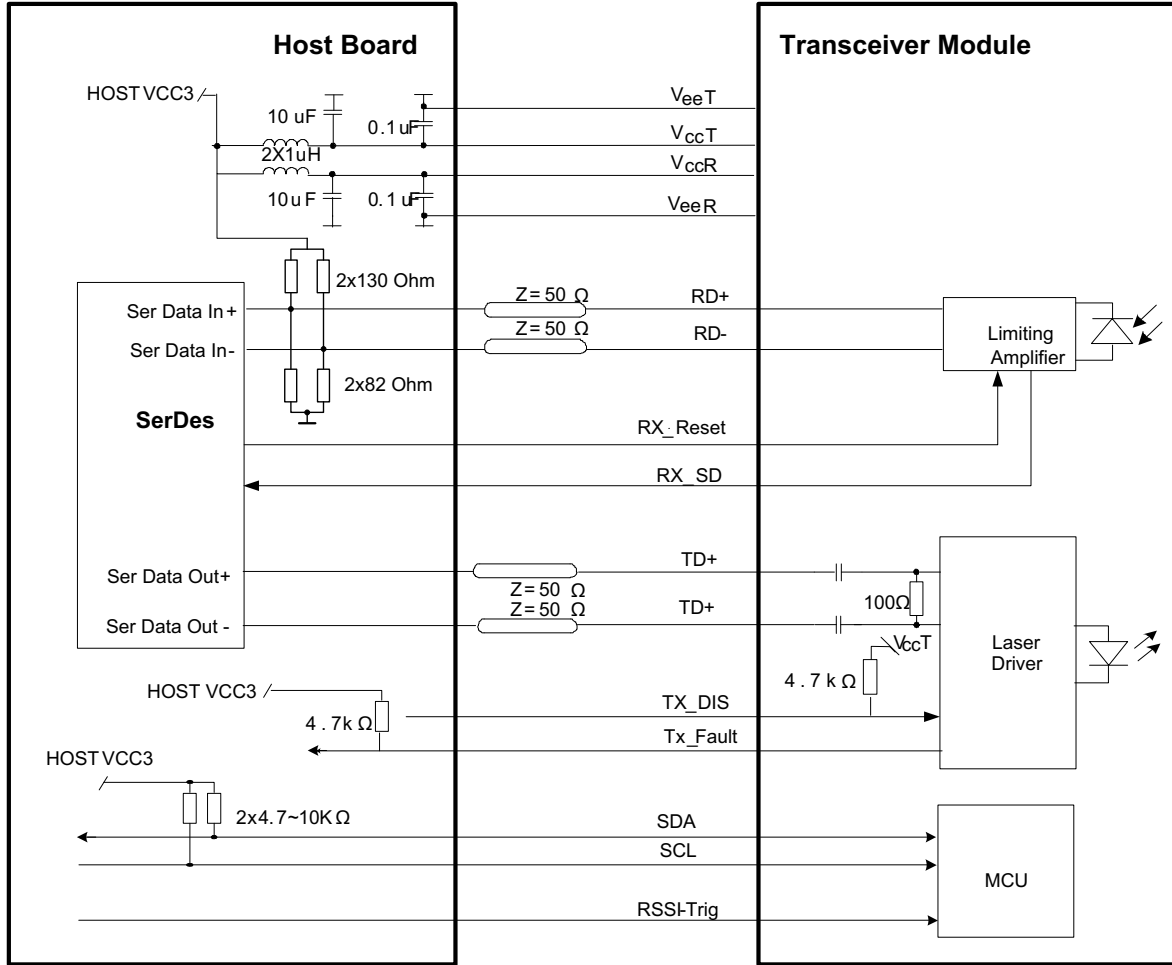

## Mechanical Diagram

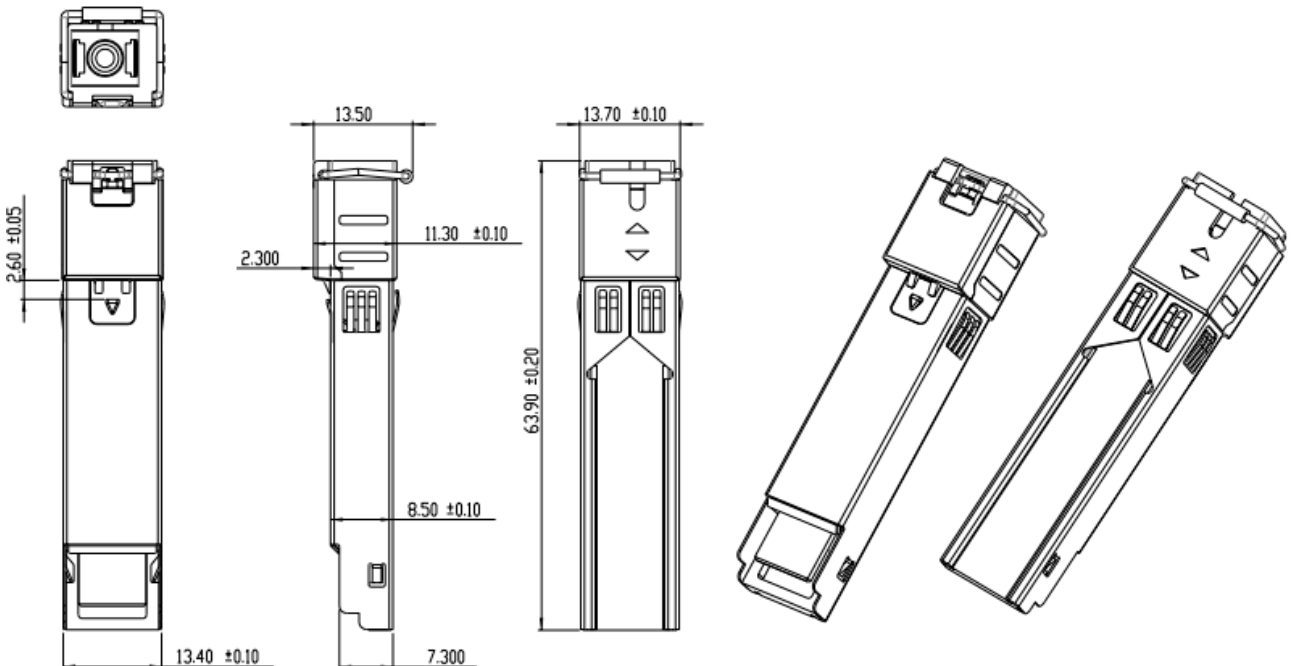



**Optinet Technology Co., Ltd**

Add: 4th Floor Xiufeng Industrial Park, Buji Street, Longgang District, Shenzhen, China 518112

Tel: +86-755-28471034 Fax: +86-755-61824579

www.optinetec.com sales@optinetec.com

## Ordering Information

P/N	Product Description
OP-GPON-C+++	GPON OLT C+++ SFP Module, 2.488Gbps TX1490nm, 1.244Gbps RX1310nm, 20km SC/UPC, 0~70°C Commercial Temperature
OP-GPON-C+++E	GPON OLT C+++ SFP Module, 2.488Gbps TX1490nm, 1.244Gbps RX1310nm, 20km SC/UPC, -10~85°C Extended Temperature
OP-GPON-C+++I	GPON OLT C+++ SFP Module, 2.488Gbps TX1490nm, 1.244Gbps RX1310nm, 20km SC/UPC, -40~85°C Industrial Temperature